

'ENGLISH ELECTRIC'

Diesel-electric Traction Series • No. 103

BRITAIN'S FIRST MAIN-LINE DIESEL-ELECTRIC LOCOMOTIVES

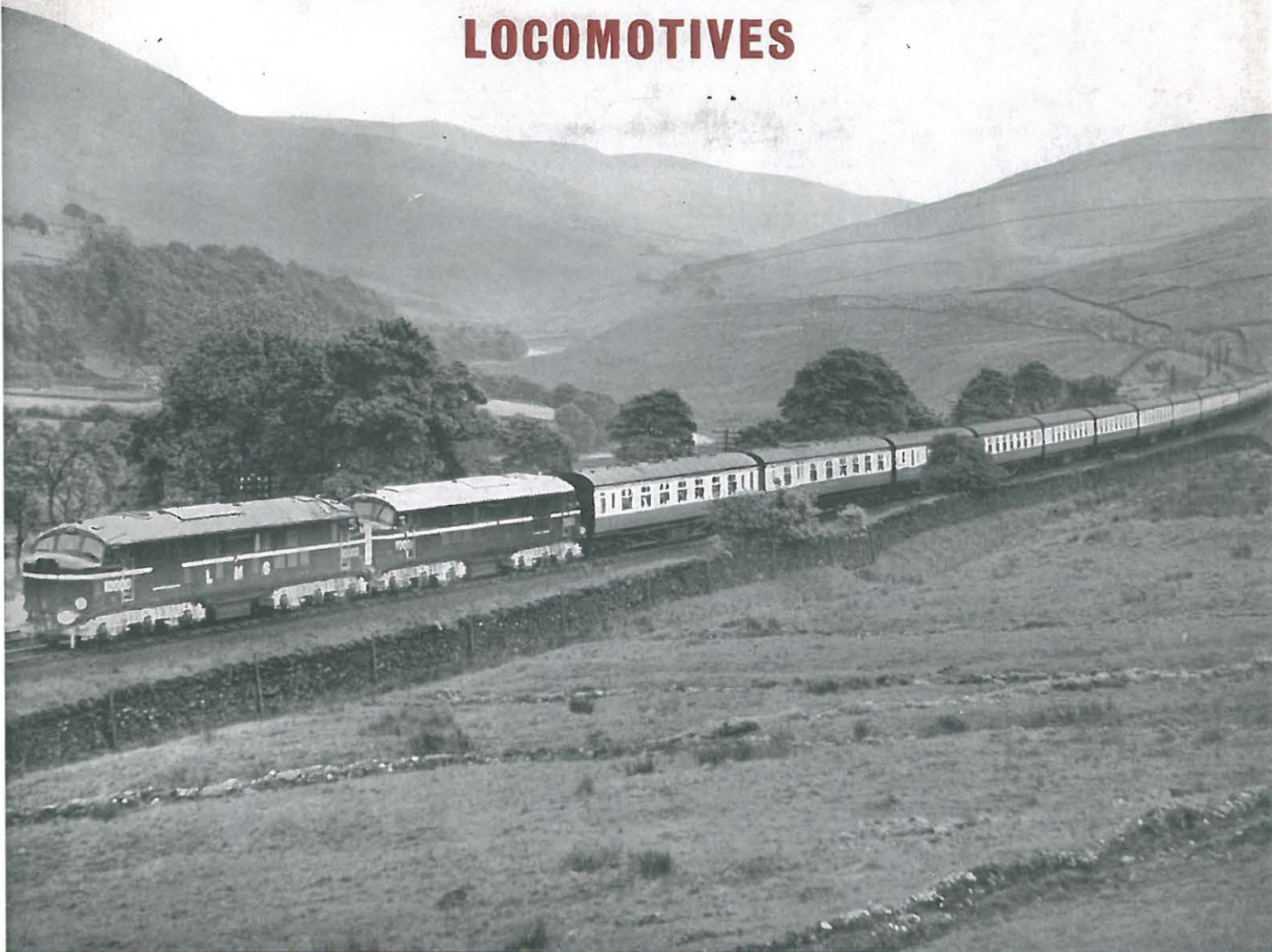

The ENGLISH ELECTRIC Company Limited

Traction Department . . . London and Bradford

Works: STAFFORD · PRESTON · RUGBY · BRADFORD · LIVERPOOL · ACCRINGTON

Front Cover Illustration: "Royal Scot" London-Glasgow express beginning the climb to Shap Summit hauled by locomotives Nos. 10000 and 10001. The sixteen-coach train has a gross weight of 545 tons

'ENGLISH ELECTRIC'

Diesel-electric Traction Series • No. 103

BRITAIN'S FIRST MAIN-LINE DIESEL-ELECTRIC LOCOMOTIVES

General

In April 1947, an agreement was signed between The English Electric Company, and the then London, Midland and Scottish Railway, providing for the construction of two 1600 h.p. diesel-electric locomotives, to enable trials to be carried out with this type of motive power on main line passenger and freight duties. The diesel and electrical equipment for these locomotives was designed and built by The English Electric Company, and erected on mechanical parts designed by Mr. H. G. Ivatt—formerly Chief Mechanical Engineer, London Midland Region—and built at Derby Locomotive Works. Locomotive No. 10000 was completed in December 1947, and the second locomotive, No. 10001, in July 1948.

Principal Dimensions

Wheel arrangement	Co-Co
Length over buffers	61 ft 2 in.	
Overall width	9 ft 3 in.	
Overall height from rail level	12 ft 11½ in.	
Total wheelbase	51 ft 2 in.	
Bogie wheelbase (rigid)	15 ft 8 in.	
Wheel diameter	42 in.	
Weight in working order (adhesive)	127 tons 13 cwt.	
Maximum axle loading	21 tons 5 cwt.	
Number of traction motors	6	
Gear ratio	55/18	
Maximum starting tractive effort	41,400 lb.	

One hour tractive effort	18,500 lb. at 26 m.p.h.
Continuous tractive effort	15,000 lb. at 32 m.p.h.
Maximum service speed	... 93 m.p.h.

Mechanical Parts

The locomotives are of the double-bogie end cab type, each bogie having three motored axles. The bogies are not articulated, the tractive forces being transmitted through the underframe. A novel design of bolster-type bogie was evolved for these locomotives as the available clearances with the orthodox type would not have been sufficient to enable a traction motor to be mounted on the centre axle. To obviate this difficulty the locomotive weight is carried on sliding surfaces at four points on the axes of the bolsters, enabling the member connecting the bolsters to the centre pivot to be of lighter section than in the normal bolster type of bogie, the bogie pivot only being required to deal with location and tractive forces. This reduction in the normal thickness of this member permits adequate clearances for mounting a traction motor on the centre bogie axle. The axleboxes have side-projecting lugs which press against spring-loaded pads on the bogie frames, cushioning any excessive transverse forces transmitted from the wheels. The excellent riding qualities of these locomotives at high speeds, and on routes where considerable reverse curvature exists, provide adequate testimony to the bogie design and suspension.

The longitudinal frame members are braced by cross stretchers which form supports for mounting the engine generator unit and other equipment. A

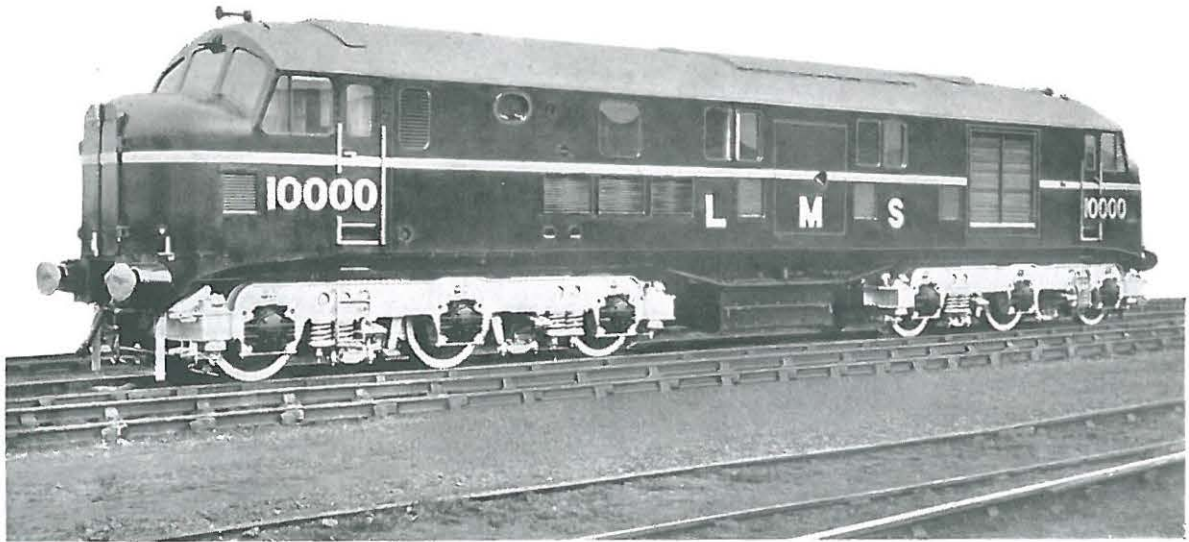

Fig. 1 Close-up view of 1600 h.p. main-line diesel-electric locomotive

sealing plate runs the full length of the locomotive to prevent any leakage of oil and water on to the bogie and underframe-mounted equipment. An aluminium floor-plate runs from one driving cab to the other providing ready access to the engine and equipment compartments.

The centre superstructure of the locomotive forms one assembly, which extends between the inner cab bulkheads, and is supported on two pivots at the bulkheads behind the driving compartments, thereby preventing stresses in the underframe being transmitted to the superstructure. The cab and nose-end sections are mounted independently from the centre superstructure, which may be removed in one section without interference with the cab and nose-end sections. Hinged doors are provided in the roof of the centre superstructure to facilitate diesel engine inspection and maintenance. The cab layout has been evolved to give maximum visibility and convenient positioning of controls. Adjustable upholstered seats are provided for the locomotive crew, also windscreen wipers, defrosters and sun blinds.

The locomotives are equipped with vacuum brakes actuated from brake valves in the driver's cabs. Each locomotive is fitted with two Westinghouse

type 3V72 motor-driven exhausters. Hand braking is also provided, actuated from handwheels in the cabs. A Clarkson oil-fired train-heating boiler provides steam for carriage warming when required.

The general arrangement of the locomotives is clearly shown in the elevation and plan, Fig. 5.

Diesel Engine

The diesel engine, main generator and auxiliary generator form one unit which is supported on resilient mountings. The pressure-charged four-stroke V-type engine has sixteen cylinders, 10 in. bore \times 12 in. stroke and is rated for this application at 1600 b.h.p. at 750 r.p.m. The brake mean effective pressure is 112 lb. per sq. in., and the piston speed 1500 ft. per min. at full load. Fuel consumptions at full, 75 and 50 per cent. load are 0.40, 0.389, and 0.402 lb. per b.h.p. hour respectively, based on a minimum calorific fuel value of 19350 B.Th.U. per lb. The maximum cylinder pressure is about 760 lb. per sq. in. The rating of this type of engine can be increased to 1760 b.h.p. at the same engine speed by increasing the fuel injected and to 2000 b.h.p. at 850 r.p.m.

The general design of the engine is based on the very successful "English Electric" naturally-aspirated

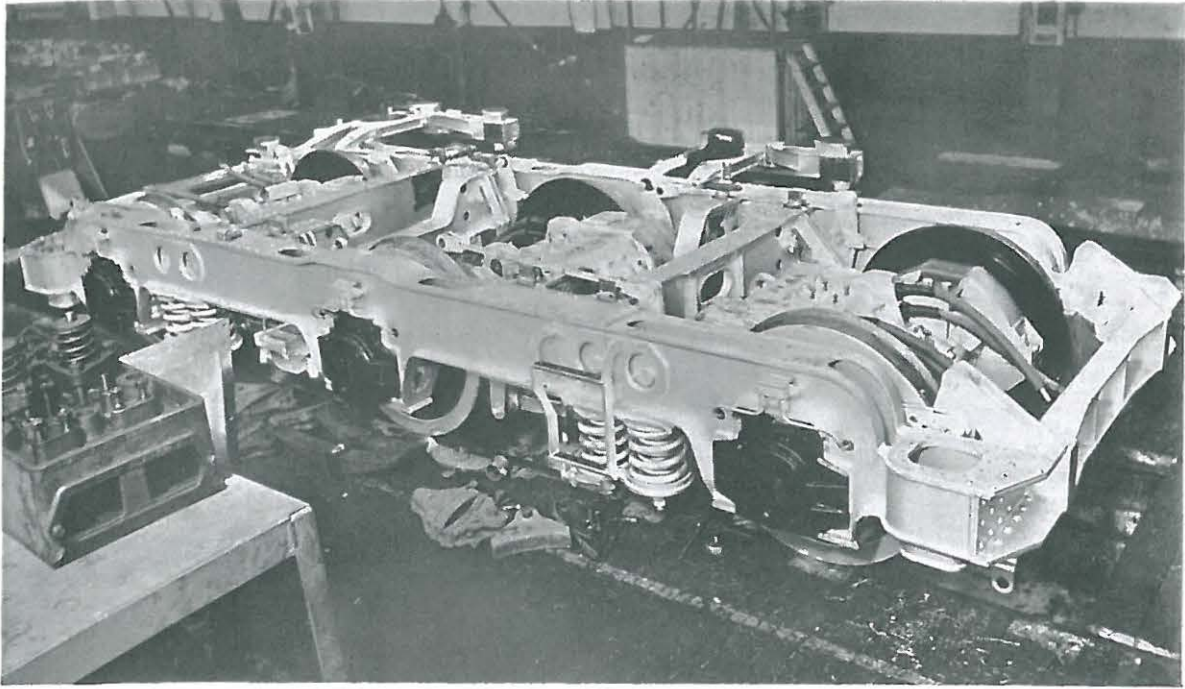

Fig. 2 Completed motor-bogie showing traction motors

in-line type used in the 350/400 h.p. standard diesel-electric shunting locomotives, of which 236 will be in service on British Railways alone when present orders are completed. The use of pressure-charging increases the engine power output by about 50 per cent. compared with a naturally-aspirated engine of similar type. Each of the four British Brown-Boveri turbo-chargers fitted to these engines serves four cylinders and has an automatic lubricating system, which is entirely independent of the main engine system. The turbo-charger exhaust manifolds are located between the cylinder banks.

Two mechanically-driven water circulating pumps are provided, one to each bank of cylinders, also two lubricating oil pumps and a fuel transfer pump. The pump drives are taken from the free end of the engine crankshaft. One of the lubricating oil pumps draws oil from the engine sump and circulates it through the oil radiator, the second pump drawing oil from the radiator circuit and delivering it through filters to the main crankshaft bearings, from which it passes through drillings in the crank-

shaft to the connecting-rod big-end and gudgeon-pin bearings. Forced lubrication is also provided to the camshaft bearings and to the camshaft and pump drives. The valve gear is lubricated at reduced pressure from the main engine system.

The engine governor regulates the quantity of fuel delivered by the fuel pumps by means of a servo piston operated from the lubricating oil system, any failure in which automatically shuts down the engine. The governor is driven from one of the camshafts at the flywheel end.

The engine is started by motoring the main generator from a 60-cell, 236 ampere-hour, D.P. Kathanode battery, until the engine fires. Engine protective features include an engine over-speed trip device and a switch which inserts a limiting resistance in the generator field circuit to reduce the generator output in the event of a turbo-charger failure.

Twin Serck radiators are fitted, consisting of headers and oil and water-cooling elements. The water

sections of the radiators are thermostatically controlled, but temperature control can also be exercised by means of shutters on the outside of the radiators.

The main fuel tanks have a total capacity of 815 gallons and are located on both sides of the locomotive, adjacent to the radiators. The service fuel tank has a capacity of 85 gallons and is located above and fabricated with the main tanks. Fuel is normally transferred to the service tank by a mechanically-driven fuel transfer pump, but a semi-rotary hand pump is also provided for use when the engine is not running. Filling points for fuel and water tanks are provided at platform level, with additional filling points in the locomotive roof.

Air for engine combustion is drawn in through four sets of Vokes filters, located in the body sides, coupled to air trunking leading direct to the turbochargers.

Electrical Equipment

The main generator is bolted and registered to a facing formed by an extension of the engine bedplate at the flywheel end. It is a single-bearing self-ventilated machine direct-coupled to the engine crankshaft and has a continuous rating of 1080 kW at 650 volts, 1660 amperes. Two separately-excited field windings and a series decomposing winding are provided, the latter also being used when the main generator is motored from batteries for engine starting purposes.

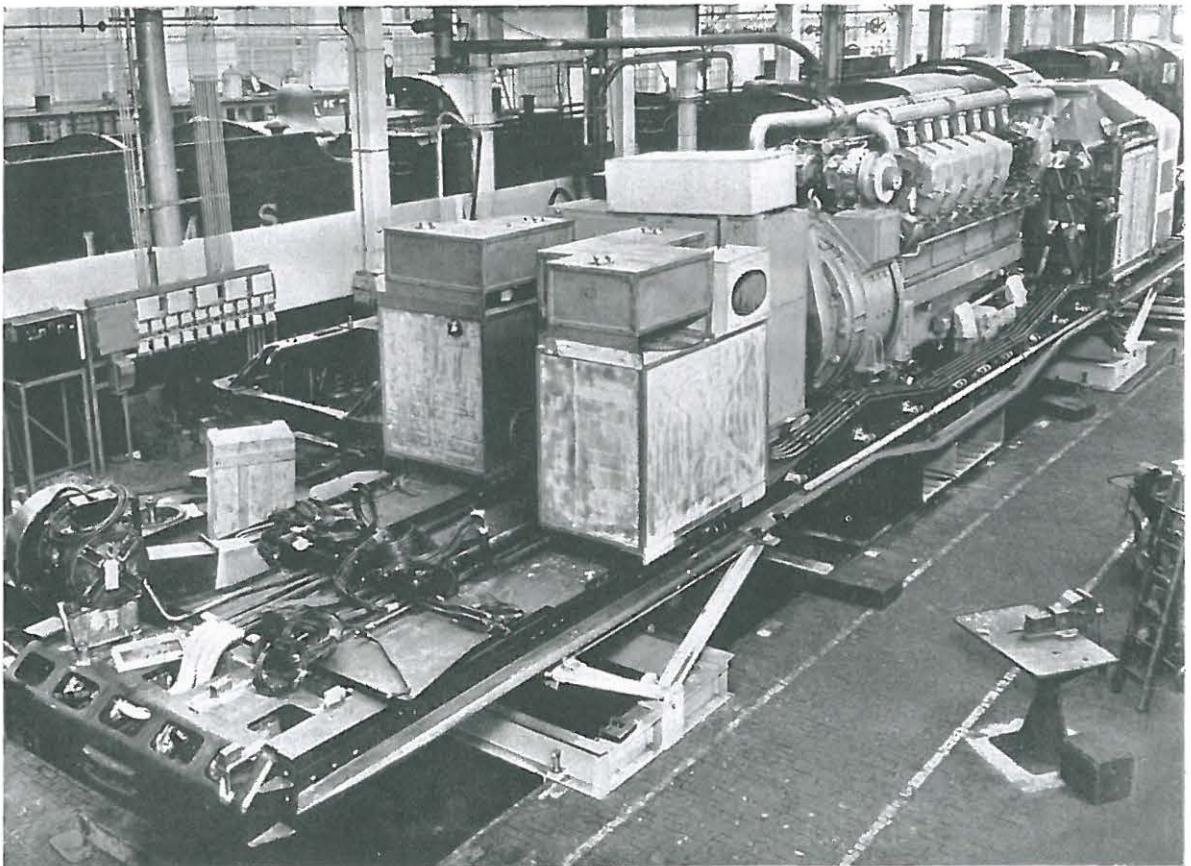

Fig. 3 Main frames showing engine-generator unit, control cubicle, radiator and fan ducting, also fuel and water tanks for engine and heating boiler

The main generator supplies current to six nose-suspended, series-wound, traction motors which drive the road axles through single-reduction spur gearing. The traction motors have a continuous weak field rating of 220 h.p., 300 volts, 550 amperes, and are connected in three parallel groups of two motors in series. Two blowers, one mounted in each nose-end compartment, each provide forced ventilation to the three motors in the bogie below.

The shunt-wound auxiliary generator is overhung from the main generator and is continuously rated at 50 kW, 135 volts, 375 amperes. It supplies current for the control circuits, excitation of the separately-excited fields of the main generator, battery charging, motor-driven compressors and

exhausters, blower motors, and locomotive lighting. The radiator fan is driven by a vertical-spindle motor taking current from the main generator.

The dust-proof control cubicle houses the electro-pneumatic and electro-magnetic contactors, reverser and associated relays and fuses. The compartment in which the control cubicle is mounted is separated from the engine compartment by a bulkhead with air-tight doors. The main and auxiliary generators project through this bulkhead into the compartment housing the control cubicle, and draw their cooling air through Vokes filters mounted in the body sides. This air is discharged into the engine room and escapes to atmosphere through louvres in the roof and sides of the engine room.



Fig. 4 Locomotive approaching completion showing motor bogies and centre superstructure in position

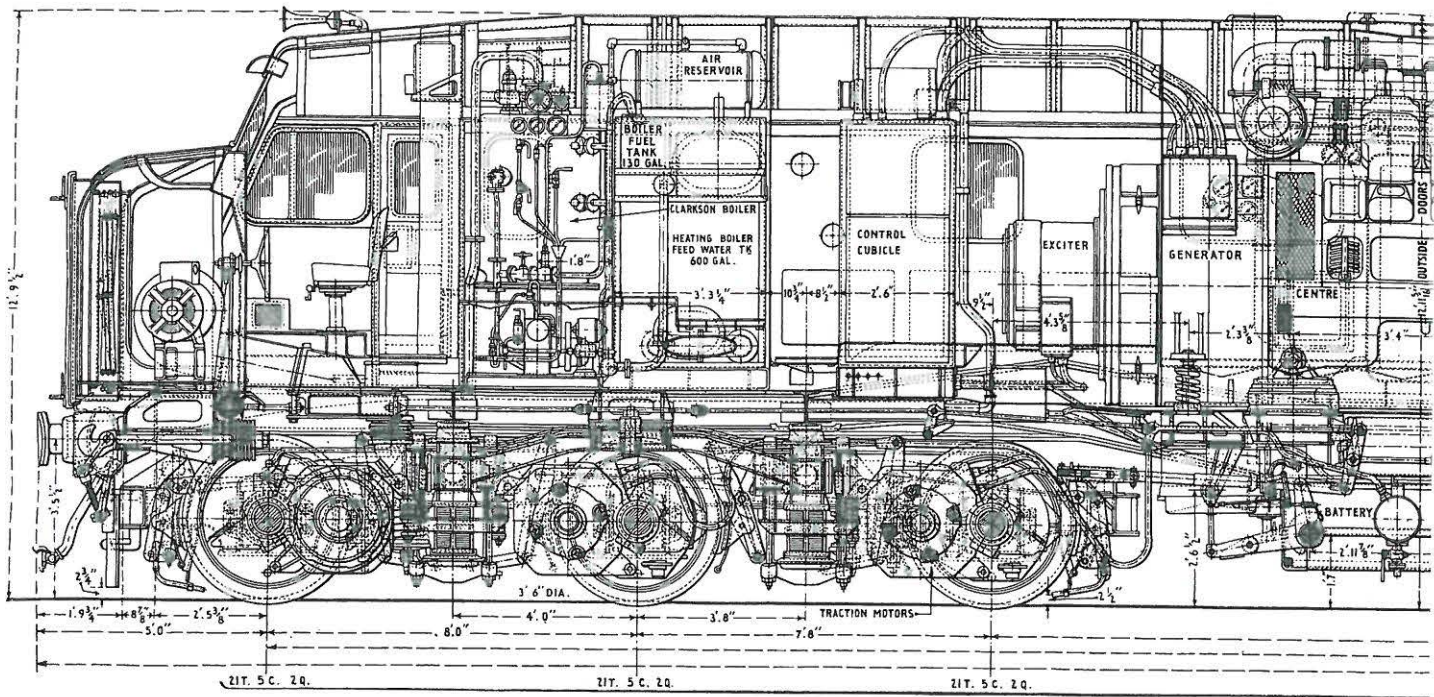

TOTAL WEIGHT IN

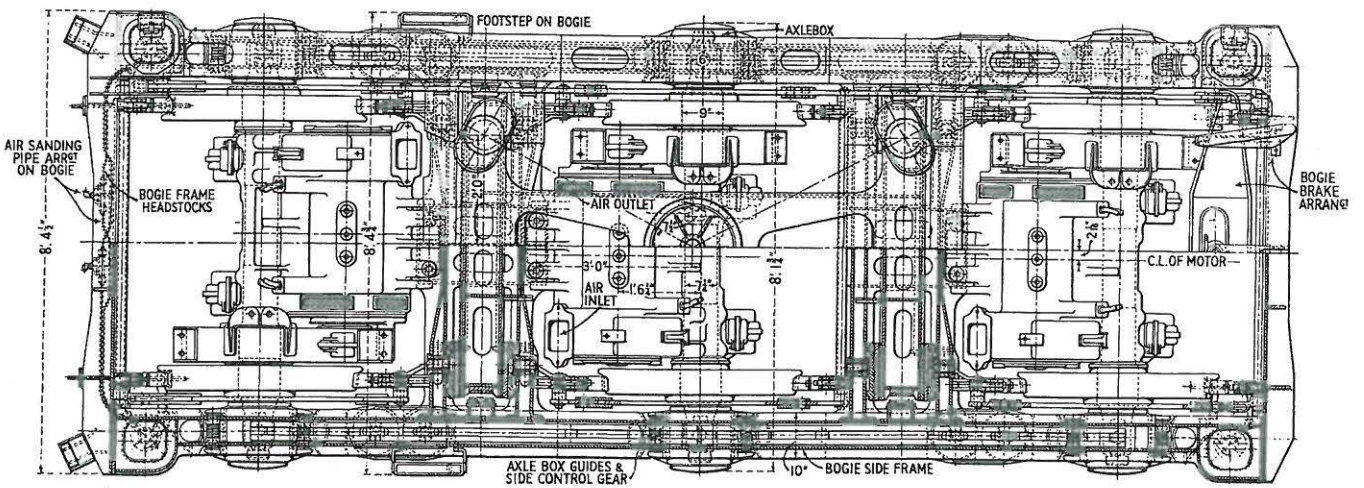
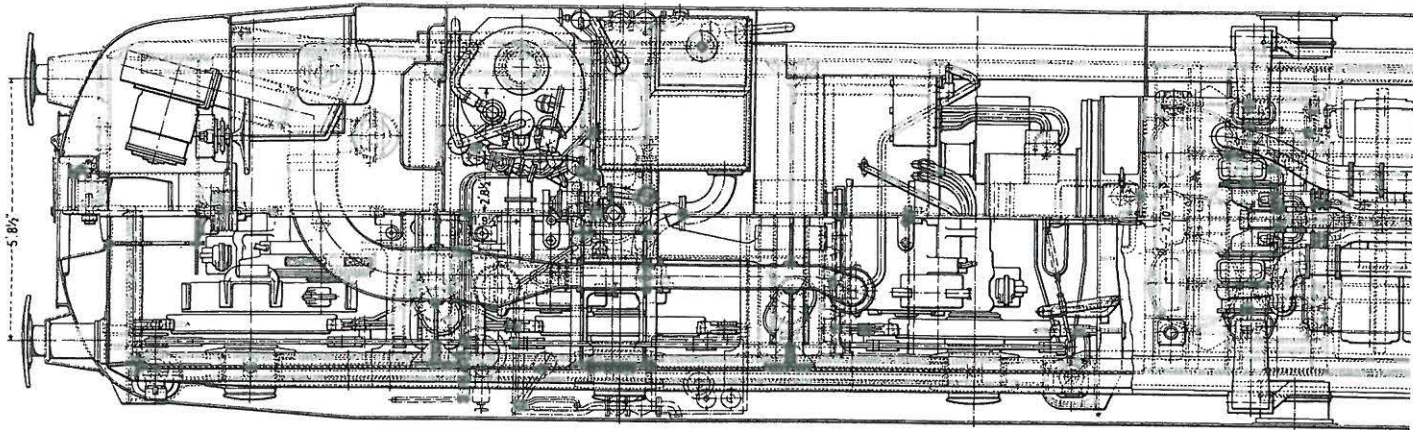

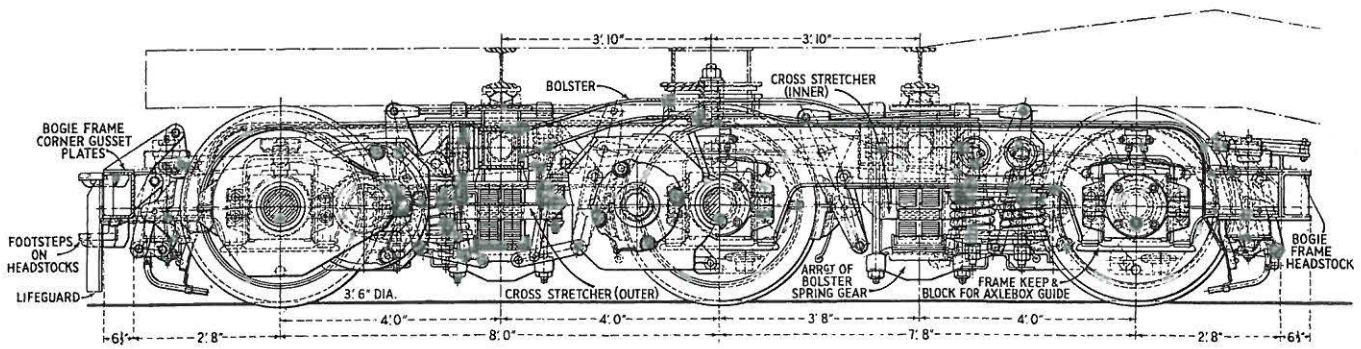
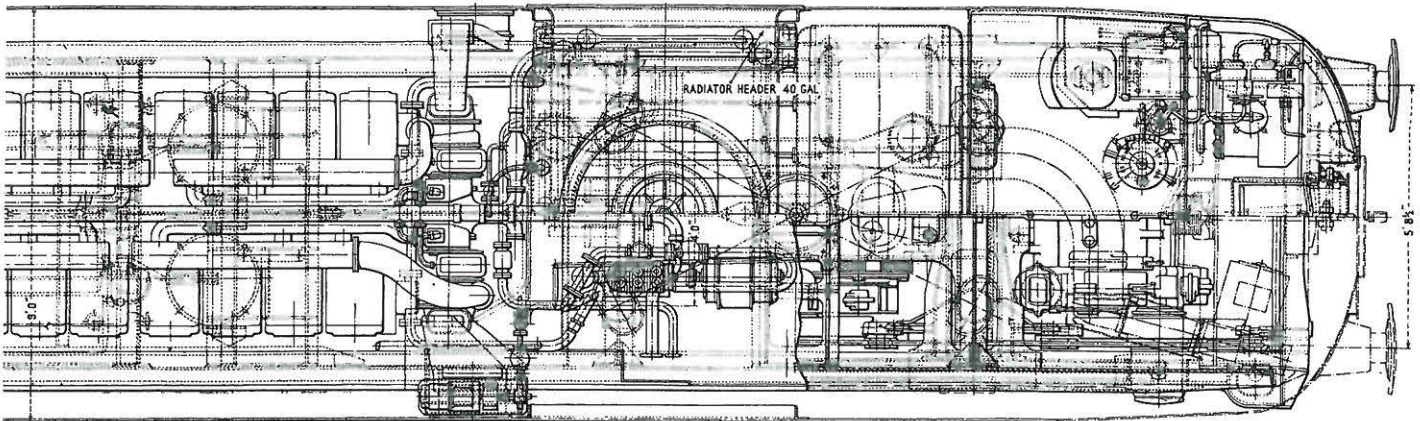
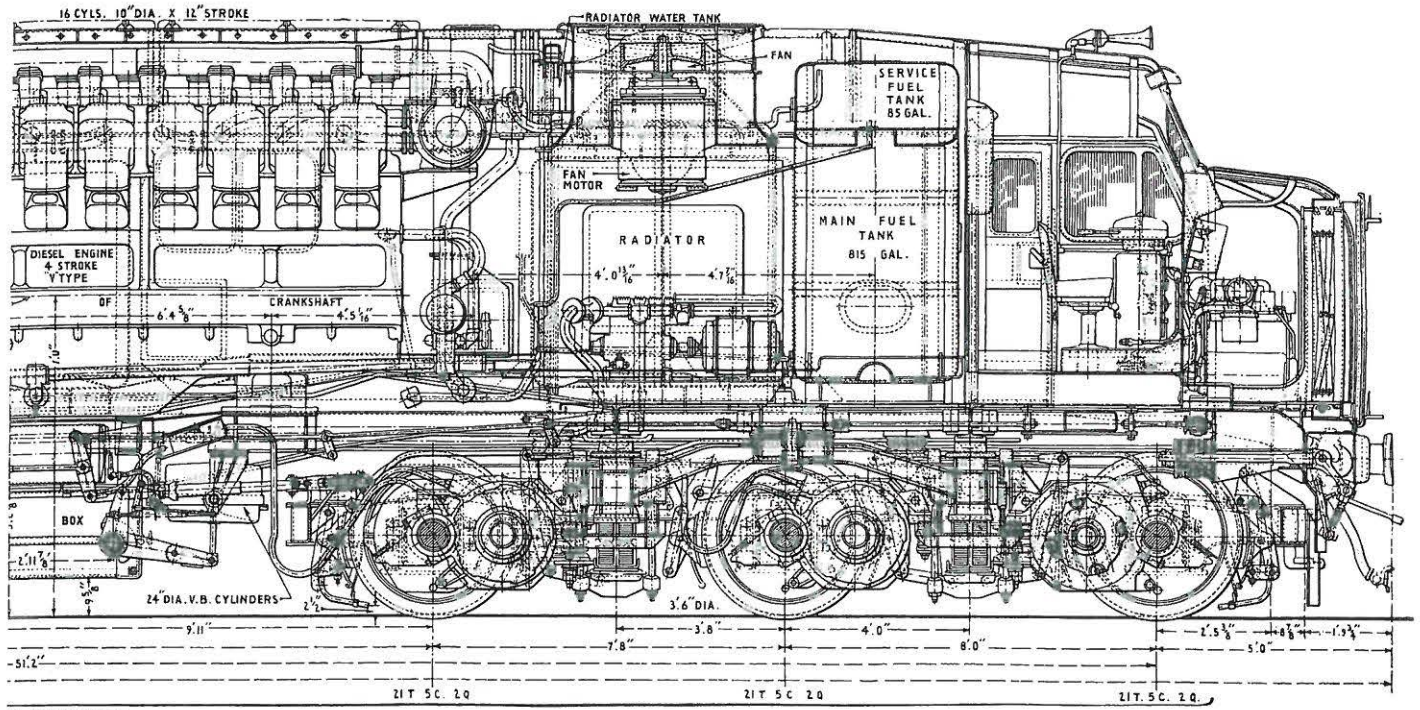

Fig. 5 Elevation and plan arrangements of 1600 h.p. main-line diesel-electric locomotive

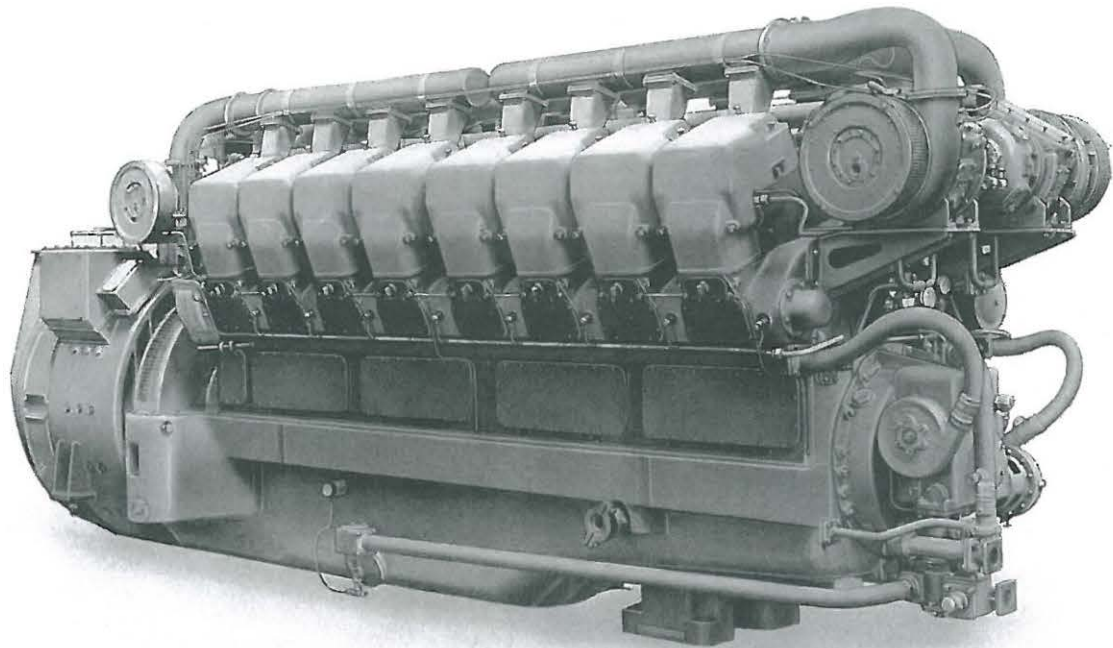

Fig. 6 Engine-generator unit comprising 'English Electric' 1600 h.p. supercharged diesel engine, main generator and auxiliary generator

Operation

The cab-mounted master controllers incorporate a main control handle, reverser, and master switch. The control handle is used to regulate the output of the engine-generator unit according to power requirements. It has eight notches corresponding to progressively increased generator power outputs, which are obtained by the use of engine speeds of 450, 620 and 750 r.p.m., in conjunction with varying degrees of main generator field excitation. The master switch controls the starting and stopping of the diesel engine.

The use of these controls may be illustrated by describing the sequence necessary to move the locomotive from rest. The diesel engine is started by moving the master switch to the "start" position and, when it fires, to the "engine only" position, in which the diesel engine may be run, without

excitation of the main generator fields. To move the locomotive the reverser must first be set to the appropriate direction of motion and the master switch to the "on" position. This latter movement makes the necessary connections to enable the main-generator fields to be energised. The locomotive is now controlled by the main control handle, which is advanced by steps to the appropriate notch corresponding to the power output required. When the control handle is in the eighth notch an automatic device is brought into action, adjusting the excitation of the main generator so that its output corresponds to the available engine horsepower, irrespective of locomotive speed.

Performance and Service Running

The performance characteristic for one of these locomotives (Fig. 8), shows the tractive efforts

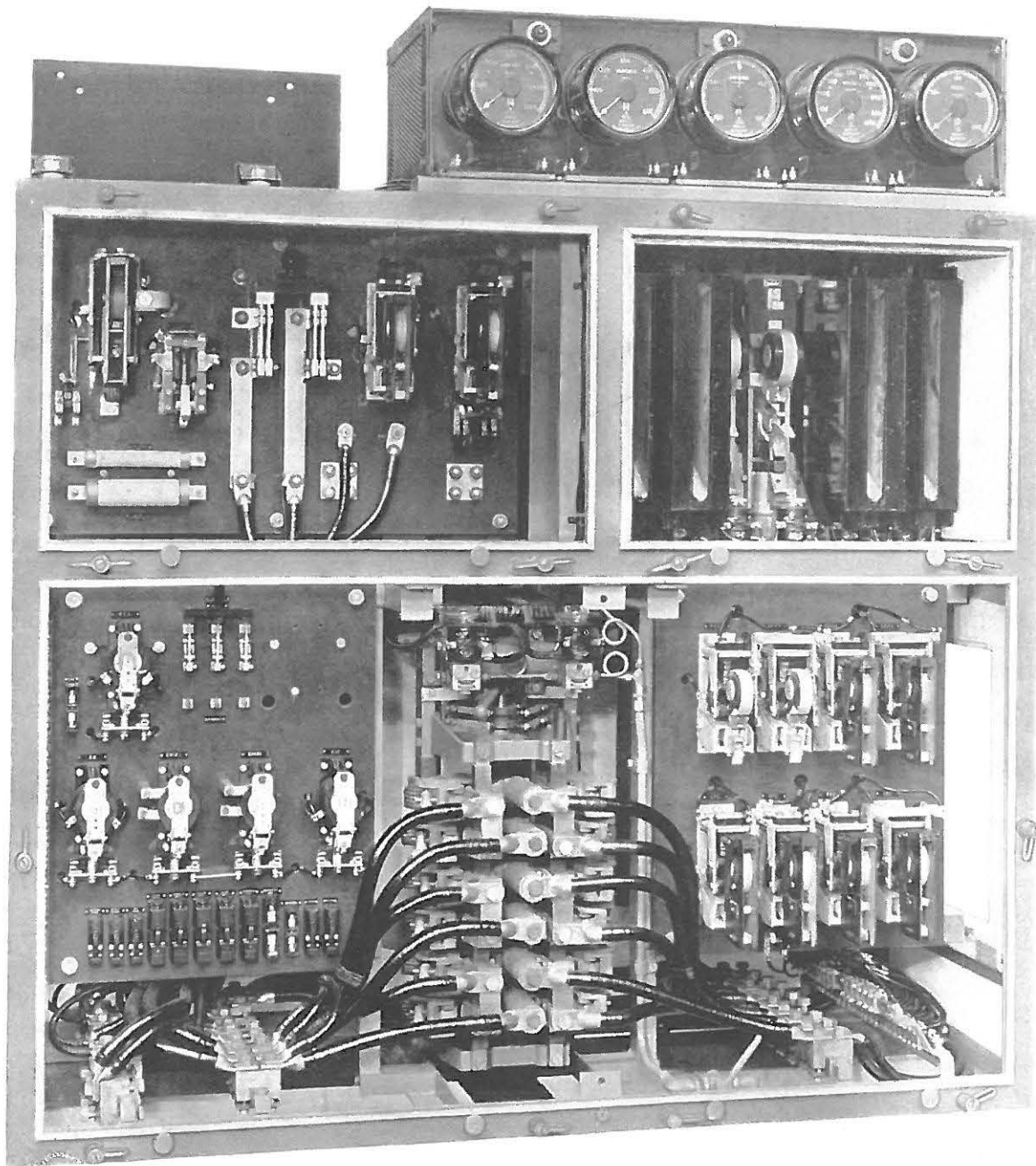

Fig. 7 Front view of main control frame

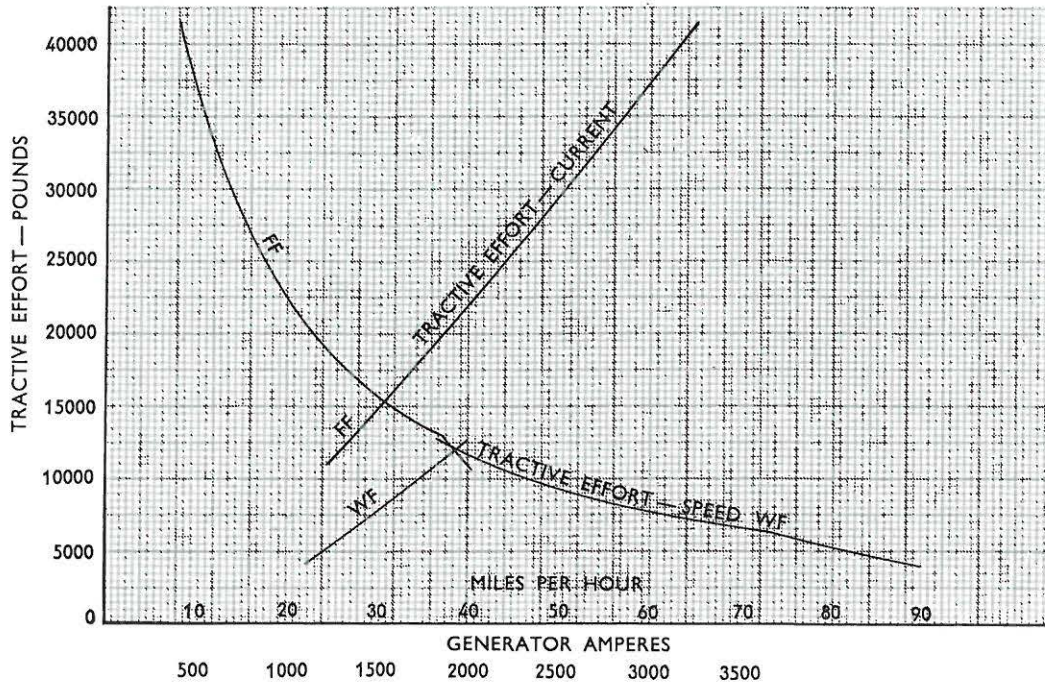

Fig. 8 Speed/tractive-effort characteristic for 1600 h.p. diesel-electric locomotive

obtainable at varying speeds. The high starting tractive effort of these locomotives, combined with total adhesion, makes their capacity for rapid acceleration from rest effective under all weather conditions.

The introduction of these locomotives created a deep impression, both in railway circles and among the general public and their first months of service running were followed with close interest.

Following preliminary trials, locomotive No. 10000 commenced regular working between London (St. Pancras) and Derby, 128.5 miles, in February 1948, with express passenger trains of between 300 and 450 gross tons weight. During the subsequent five months this locomotive covered a total of 57,041 miles on these duties; for the major part of the time making two return trips daily between Derby and London, a total of 514 train miles. At that time a number of severe permanent way slacks were in force between St. Pancras and Leicester and, as these often caused up to 15

minutes delay in the running on each journey, the exemplary timekeeping of trains hauled by this locomotive was the more creditable. Locomotive No. 10001 when completed, was also put into service on this run, the locomotive rosters being extended to include the Derby-Manchester route, through the Peak District, which has long gradients of 1 in 90 to 1 in 100.

Towards the end of 1948 both locomotives were withdrawn from traffic to enable a number of minor modifications to be carried out in the light of experience gained. The locomotives had, however, already shown their ability to maintain high daily mileages and availability, combined with a comfortable mastery over the schedules which they were required to operate. Subsequently both locomotives were again put into single-unit operation on the Midland Division before being transferred to the Western Division for multiple-unit operation of heavy express passenger trains between Euston, Carlisle, and Glasgow.

On June 1, 1949, the two locomotives hauled the sixteen-coach "Royal Scot" express, weighing 545 gross tons, non-stop over the 401.4 miles from Euston to Glasgow, making a similar run in the reverse direction the following day. For the major part of the distance it was not necessary to utilise the full engine output to maintain schedule, despite a number of permanent way and signal checks which caused loss of time. On the ascents to Shap and Beattock Summits, however, full engine output was used; the minimum speeds in each case, on lengthy gradients averaging 1 in 75, being 38 and 36 m.p.h. respectively.

The high-speed possibilities with these locomotives when operating in multiple unit were well demonstrated on a run in ordinary service between Euston and Carlisle. A number of severe delays were experienced en route, but the train arrived at Carlisle sixteen minutes early having covered the 299.1 miles in a net running time of 292 minutes, an

economy of 74 minutes on the schedule then in force. South of Crewe speeds of 64 to 66 m.p.h. were sustained up lengthy gradients of 1 in 330 to 350 with a train of 530 gross tons. Between Crewe and Carlisle the trailing load was reduced to 390 gross tons and one of the fastest climbs on record was made between Carnforth and Shap Summit, in which the line climbs 915 feet in 31.4 miles. This section was covered at an average speed of 63.2 m.p.h. with minimum speeds of 58 m.p.h. on the 1 in 106 gradient of Grayrigg Bank and 49 m.p.h. on the 1 in 75 of Shap incline.

Following the successful non-stop London-Glasgow journeys already mentioned, the two locomotives went into regular multiple-unit service on this route and in the next two-and-a-half months each covered 33,590 train miles, with average trailing loads of 476 tare tons. At first they made a round trip daily between London and Carlisle, 598 miles, and later between London and Glasgow, 803



Fig. 9 In freight service. Locomotive No. 10000 hauling the 2.40 p.m. Camden-Crewe express freight train



Fig. 10 Twin 1600 h.p. diesel-electric locomotives hauling "Royal Scot" Glasgow-London express

miles. On the Glasgow roster the north-bound trip was made with the very heavy 9.5 p.m. Euston-Glasgow sleeping car train, weighing up to 545 tare tons, returning with the up "Royal Scot". The daily locomotive mileage of 803 involved has never been exceeded in this country. These workings were resumed in the summer of 1950 when the locomotives each covered 69,213 train miles in just over four months, the trailing loads averaging 472 tare tons.

The ability of a single unit locomotive to haul heavy passenger trains, which had already been shown on the Midland Division, was further demonstrated in the autumn of 1949 when locomotive No. 10000 successfully worked daily round trips between Euston and Blackpool (230 miles)

with trains averaging 396 tare tons, twice rising to 445 tare tons. In the summer of 1951, locomotive No. 10001 made trial runs between Euston and Glasgow with heavy passenger trains and subsequently both locomotives have been in regular single unit service on heavy passenger trains between London and Crewe, Liverpool and Blackpool. The average loading of these trains is about 450 gross tons, and the scheduled speed between stops 50-55 m.p.h. The rosters worked by these locomotives involve daily train mileages of up to 703. During fifteen weeks operation on these services in the summer of 1951, locomotive No. 10001 covered over 38,000 miles. On a recent run with the "Red Rose" express from Liverpool to Euston with a trailing load of 490 gross tons, locomotive No. 10001 converted a four minutes late start from

Crewe into a five minutes early arrival at Euston, despite signal and permanent way slacks en route, the net time for the 158.1 miles from Crewe to Euston being only 157 minutes, against 175 scheduled. On this run the minimum speed up the 1 in 333 grade to Tring was 56 m.p.h. and a maximum speed of 82 m.p.h. was attained down a similar gradient.

In addition to the passenger train workings already mentioned, these 1600 h.p. main-line diesel-electric locomotives have been employed singly for lengthy periods on haulage of fast freight trains between London and Crewe. These rosters normally involved working the 2.40 p.m. express freight train between London (Camden) and Crewe, returning with a Crewe-Willesden freight train the following morning, a train mileage of 308 daily. The 2.40 p.m. Camden-Crewe working is one of the fastest freight trains in the country, being scheduled at 45 m.p.h. over this 156 mile section. The gross loading frequently exceeds 500

tons and this, combined with the increased rolling resistance of four-wheel freight stock, make it an onerous duty. Nevertheless locomotives Nos. 10000 and 10001, showed themselves quite capable of maintaining schedule without exceeding the 60 m.p.h. speed limit for fast vacuum-fitted freight trains. On the more easily timed return journey, loads of up to 800 gross tons have been hauled successfully and, on one occasion when normal freight workings were disorganised by fog, a 60-wagon coal train weighing some 1100 gross tons was hauled between Rugby and Willesden, 25 m.p.h. being sustained on the 1 in 333 gradient to Tring Summit. These performances were achieved without alteration to the gear ratio, which was primarily intended for high-speed passenger service, and testify to the versatility of these locomotives and to their robust design.

Acknowledgment is given to British Railways, by whose courtesy the arrangement drawing and several illustrations are reproduced.

THE 'ENGLISH ELECTRIC' COMPANY LIMITED

GENERATING PLANT FOR STEAM, WATER OR OIL POWER

Complete Power Stations of any size. Steam Turbines and Turbo-alternators. Surface Condensers. Feed Heating Plant. Horizontal and Vertical Water-turbines and Alternators. 4-stroke cycle Diesel Engines. Gas Turbines. Alternators and D.C. Generators for all forms of drive. High-voltage D.C. Generators for Radio Transmitting Stations.

ELECTRIC TRACTION AND TRANSPORT

Complete Electric Traction Systems. Rectifier Sub-stations. Electric Locomotives. Electric Motor-coach stock. Diesel-electric Locomotives. Diesel-electric stock. Track Motors and Control Equipment for Railway or Road Vehicles. Battery Locomotives. Industrial Locomotives for all services. Diesel-electric Railcars. Electric Tramcars. Electric Trolleybuses. Tramcar Trucks.

EQUIPMENT FOR MARINE PURPOSES

Steam Turbine, Diesel Engine and Gas Turbine Equipment for ship propulsion. Diesel-electric and Turbo-electric Generating Sets for ships' auxiliaries. Motors for auxiliary drives.

AIRCRAFT AND AIRCRAFT ELECTRICAL EQUIPMENT.

TRANSMISSION SYSTEMS, SWITCHGEAR AND CONTROL EQUIPMENT

Complete Indoor or Outdoor Switching Stations. Air-blast Switchgear. Air-break Switchgear. Oil Circuit-breakers up to highest breaking-capacities. De-ion Grid Contacts for Arc Control. Metal-clad Switchgear. High-rupturing-capacity Fuse Units. Transformers of any output, voltage and type. Arc Furnace Transformers. Arc Welding Transformers. Booster Transformers. Flameproof Transformers. Hand-lamp Transformers. Instrument-transformers. Machine Tool Lighting Transformers. Radio Transformers. Arc Suppression Coils. Current-limiting Reactors. Induction Regulators. Instruments (Switchboard and Portable). Polyphase Meters. Industrial Electronic Devices. Ignition Testers.

SUB-STATIONS AND CONVERTING PLANT OF ALL KINDS

E.H.V. and L.V. Switchgear of all types. Automatic Switching Equipments. Fuse Gear. Mercury-arc Rectifiers, steel-tank and steel-bulb types. High-voltage Mercury-arc Rectifiers for radio transmitters and allied applications. Frequency Changers. Motor Convertors. Motor-generators. Rotary Convertors. Synchronous Condensers.

ELECTRICAL EQUIPMENT FOR ALL INDUSTRIES

Specialists in electric drives and the complete electrification of: Iron and Steel Works. Non-ferrous Metal Works. Aircraft Factories. Arc Welding Shops. Breweries. Brickyards. Cement Works. Chemical Factories. Collieries. Cotton, Wool, Silk and Jute Mills, and all textile machinery. Dockyards. Dye-works. Engineering Shops. Farms and Dairies. Glass Works. Pulp and Paper Mills. Quarries and Mines of every description. Rubber Mills, Sewage and Irrigation Works. Shipyards. Sugar, Tea and other Food Factories.

A.C. and D.C. Motors and Control Gear in units from fractional horsepower outputs to 40,000 H.P. to meet all modern conditions of Starting Torque, Power Factor Correction, etc. Electrical Equipment for aero-dynamic research; and for testing reciprocating engines, gas turbines and their components. Ignitrons. Mercury-arc Rectifiers for electrolytic processes. Motors for Power Station Auxiliaries. A.C. Arc Welding Equipment. Stud Welding Equipment. High-frequency Equipment for Arc Welding. Battery and Trolley Locomotives.

DOMESTIC AND ALLIED APPLIANCES

Fractional Horsepower Motors. Electric Cookers. Electric Fires. Electric Food-mixers. Electric Plate-warmers. Electric Refrigerators. Electric Washing Machines. House Service Meters.

TELEVISION

Domestic Receivers. Metal Cathode-ray Tubes.

The ENGLISH ELECTRIC Company Limited

Registered Office: Queens House · Kingsway · London, W.C.2

Works: STAFFORD · PRESTON · RUGBY · BRADFORD · LIVERPOOL · ACCRINGTON

U.K. BRANCH OFFICES

Bedford, Belfast, Birmingham, Blackburn, Bristol, Cardiff, Edinburgh, Glasgow, Ipswich, Leeds, Leicester, Liverpool, London, Manchester, Newcastle, Sheffield, Slough, Southampton, Stoke-on-Trent, Swansea, Tonbridge, Wolverhampton.

OVERSEAS BRANCHES AND ASSOCIATES

Curepipe, Port Louis, N'Dola, Lourenco Marques, Launda, Accra, Lagos, Freetown, Bulawayo, Cape Town, Durban, East London, Johannesburg, Kampala, Kisumu, Mombasa, Nairobi, Port Elizabeth, Salisbury, Barbados, Buenos Aires, Ciudad Trujillo, Guayaquil, La Paz, Lima, Mexico Montevideo, Rio de Janeiro, Santiago, Sao Paulo, Caracas, Maracaibo, Trinidad, Kingston, Calgary, Edmonton, Halifax, Montreal, Ottawa, St. Catherines, Toronto, Vancouver, Winnipeg, St. John's, New York, Seattle, Bombay, Calcutta, Delhi, Karachi, Lahore, Lucknow, Madras, Colombo, Shanghai, Tokyo, Medan, Djakarta-Kota, Bandoeng, Hong Kong, Bangkok, Ipoh, Kuala Lumpur, Penang, Singapore, Sandakan, Jesselton, Adelaide, Brisbane, Melbourne, Perth, Sydney, Hobart, Auckland, Wellington, Belgrade, Copenhagen, The Hague, Helsinki, Lisbon, Oporto, Madrid, Paris, Oslo, Stockholm, Reykjavik, Athens, Nicosia, Cairo, Khartoum, Jeddah, Teheran, Baghdad, Beirut, Tel-Aviv, Ankara, Istanbul.